



I-7530A

Intelligent RS-232/485/422 to CAN Converter

Features

- Compatible with CAN specification 2.0A and 2.0B
- Fully compatible with ISO 11898-2 standard
- Support various baud rate from 10 kbps to 1 Mbps
- Jumper for 120 Ω terminal resistor
- Software configurable CAN and RS-232 / RS-422 / RS-485 communication parameters
- 1000 frames in CAN received buffer, 900 frames in RS-232/RS-422/RS-485 received buffer
- Watchdog inside
- Provide the transparent communication between the RS-232 / RS-485 / RS-422 devices via CAN bus
- Enable different RS-232 / RS-485 / RS-422 devices into an individual group in CAN bus network (Full-duplex communication mode of RS-232 / RS-422 devices is not supported)



Introduction

The I-7530A is designed to unleash the power of CAN bus via RS-232/485/422 communication method. It accurately converts messages between CAN and RS-232/485/422 networks. This module let you communicate with CAN devices easily from any PC or devices with RS-232/485/422 interface. The programmable RS-232/485/422 device (For example: PC, PLC or PAC) can use the serial port to connect to the CAN network via the I-7530A.

Hardware Specifications

CAN Interface	
Controller	Microprocessor inside with 20MHz
Connector	9-pin male D-Sub (CAN_L, CAN_H, N/A for others)
Port Channels	1
Baud Rate	10 k, 20 k, 50 k, 100 k, 125 k, 250 k, 500 k, 800 k and 1 Mbps
Protection	3000 V _{DC} power protection on CAN side, 2500Vrms photo-couple isolation on CAN bus
Terminal Resistor	Selectable 120 Ω terminal resistor by jumper
Support Protocol	CAN 2.0A/2.0B
Receive Buffer	1000 data frames
UART Interface	
COM	RS-232、RS-485、RS-422
Connector	14-pin terminal connector RS-232 : TxD, RxD, GND RS-422 : Tx+, Tx-, Rx+, Rx- RS-485 : D+, D-
Baud Rate	110, 150, 300, 600, 1200, 2400, 4800, 9600, 19200, 38400, 57600, 115200 bps
Data Bits	5, 6, 7, 8
Stop Bits	1,2
Parity	None, Even, Odd
Receive Buffer	900 data frames
Power	
Power Consumption	1W
Power Requirement	Unregulated +10V _{DC} ~ +30V _{DC} . Power reverse protection, Over-Voltage brown-out protection
LED	
Round LED	ON LED: Power and Data Flow; ERR LED: Error
Mechanism	
Installation	DIN-Rail
Dimensions	72mm x 118mm x 33mm (W x L x H)
Environment	
Operating Temp.	-25°C to 75°C
Storage Temp.	-30°C to 80°C
Humidity	10~90% non-condensing

Pin Assignments

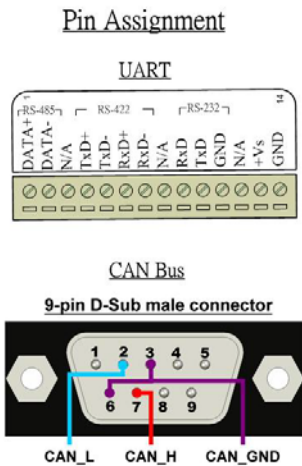

Dimensions (Units: mm)

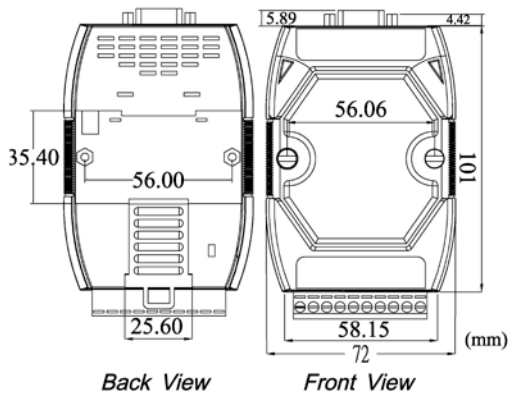

Block Diagram

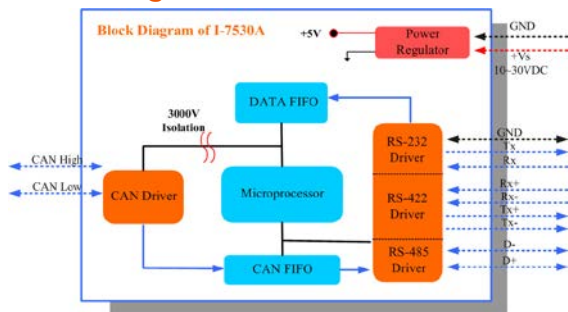

Application



Ordering Information

I-7530A-G CR	Intelligent RS-232/RS-485/RS-422 to CAN converter (RoHS)
---------------------	--

Utility Features

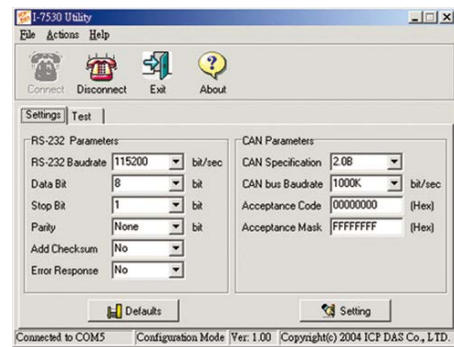

- CAN bus baud rate configuration
- CAN acceptance filter configuration
- CAN 2.0A or 2.0B specific selection
- Serial COM baud rate and data bit setting
- Serial COM command error response selection
- Utility tool for transmitting / receiving CAN messages

CAN Monitor & Data log Tools

- Show CAN messages by hex or decimal format
- CAN messages with timestamp
- Easy-to-use data logger for the diagnosis of the CAN networks and recording of the received data
- Send the predefined CAN messages manually or cyclically

